



GOVAL

Line Pressure Regulators

15^{PSIG}

*** APPLICATION NOTES ***

- A. The GOVAL regulator is ANSI Z21.80a and ANSI Z21.18 certified for vent limited installations (indoor installations where a vent line is not required) depending upon local codes and standards requirements. Per the terminology of the standard there is no "vent less regulator", they are vent limited because they can leak up to 2.5 cu.ft./hr. (1 cu.ft./hr. propane). Per code, these regulators per code can be installed without installing a vent line but again are technically termed "vent-limited" per the standard not vent less.
- B. The tables listed are guidelines in capacity. The actual capacity can differ based on inlet and outlet piping, type of equipment installed and flowing differential pressure of the system.
- C. The GOVAL is a bubble tight full lockup regulator (it will not leak gas downstream when it shuts off). Lock up of the GOVERNOR is certified to CSA ANSI Z21.80A standards. Lock up in any given installation can vary based on piping, snap-acting gas valve on high efficiency equipment, firing rate at the time of equipment shut off, debris in the line, temperature, as well as many other variables. You may see variations in lock up in some installations due to the above. Pietro Fiorentini will not guarantee the lock up will meet your equipment requirement due to these variations in installations and piping.
- D. The low capacity GOVAL 1/2" - 1" are intended for use on equipment such as unit heaters or simple on/off furnace applications.
- E. Use the high capacity GOVAL on all "high efficiency" quick-acting gas valve applications, such as generators, pool heaters, or high turn down boilers. Install a regulator on each individual piece of equipment. Size the regulator at minimum 50 to 100% over of listed capacity to minimize high lock-up.
- F. Try to match the GOVAL regulator to the pipe size of the equipment and minimize pressure drop between the regulator and equipment to 1" W.C. Minimize the amount of elbows and fittings between the regulator and the equipment and use full port ball valves not plug valves or reduced port valves.
- G. Be careful on applications where you increase the outlet piping more than 1 diameter. You may need to install an external control line in the larger piping. The GOVAL can be ordered with or retrofitted with an external control line.
- H. Make sure on all installations you don't install the regulator directly at the equipment. Install the regulator 3 to 10 feet away depending on the application.
- I. Never install the external brass vent limiter outdoors. For outdoors installation install appropriate vent protection.
- J. All GOVAL regulators include an inlet filter. The filter and/or regulator may be cleaned by removing the bottom plate Torx security screws, bottom plate assembly, then remove the filter. The filter can then be cleaned with detergent or Buna compatible solvent and dried. The valve and orifice can be cleaned with a cloth while the bottom plate is off. Then reassemble the unit.
- K. If there are ever any questions on the installation or application of the GOVERNOR regulator, immediately contact your local authorized distributor or representative.
- L. The maximum inlet pressure on the regulator label is the required maximum pressure of the CSA ANSI Z21.80 rating. It is not always the maximum allowable operating inlet pressure of the regulator. The rating is a CSA requirement.

Warranty Policy

The Seller undertakes to remedy any defects, lack of quality or non-conformity of the goods contract for which he is responsible, provided such defects have been notified in accordance within 10 (ten) days from the occurrence.

The Seller may either repair or replace the goods which have shown to be defective. In case of repair, request to return product(s) for repair must be pre-approved in writing by our Sales Department. The product(s) shall be returned pre-paid to Pietro Fiorentini USA.

Seller is not responsible for defects due to: natural wearing, Buyer's inexperience, negligence, tampering or wrong assemblage, overcome of limits conditions, non authorized intervention, force majeure or fault of the Buyer. The duration of the guarantee is twenty four months from delivery of goods.

The present warranty is not enforceable in case of lack of payment in the agreed terms. It is agreed that the obligation to repair or replace the defective goods is in lieu of any other legal guarantee or liability of the Seller, whether contractual or non-contractual, which may arise out of or in relation with the goods supplied (e.g. compensation of damages, loss of profit, recall campaigns, etc.). For goods that have been purchased from sub-suppliers, the warranty guarantee granted by them is herewith extended to the Buyer.

MATERIALS

- Body and Cover: Aluminum Alloy
- External Coatings: Polyurethane paint on request
- Diaphragm, O Rings and Valve: Nitrile Rubber
- Diaphragm Pan: Aluminized Steel

GOVAL LINE PRESSURE REGULATORS

15^{PSIG}

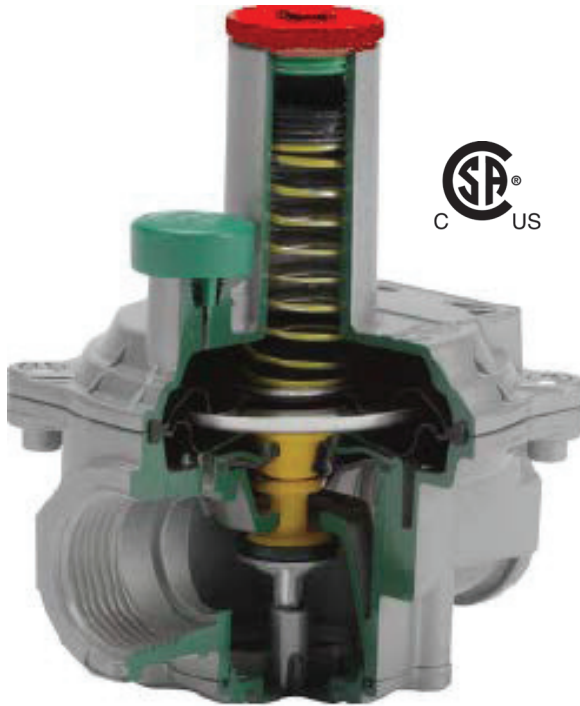

STANDARD MODEL
Inlet Pressure Range: 3" W.C. to 15 PSIG

INTRODUCTION

Pietro Fiorentini's GOVAL line of gas regulators are designed to comply with the latest CSA and international standards for regulators suitable for indoor and outdoor installations with no modifications. The GOVAL family of regulators are ideal for a wide range of residential through large industrial applications. The materials and soft parts used in the construction of the GOVAL regulators make them suitable for use with natural gas, LPG, propane air and other non-corrosive gases.

All GOVAL regulators are equipped with balanced valve design for improved high outlet pressure accuracy regardless of Inlet pressure variation. The double diaphragm with integral vent limiter provides added security. The external vent limiter reduces piping costs and the need for costly vent piping for indoor installations and complies with CSA guidelines.* The number of high capacities and regulator options sometimes eliminates the need for separate units and significantly reduces installation costs.

SAFE, RELIABLE, HIGH PERFORMANCE

- Internal vent limiter: non removable, for indoor and outdoor installations.
- External vent limiter option for indoor installations.***
- Double diaphragm for added safety and greater reliability of service.
- Balanced valve design gives you increase capacity, high 500:1 turndown and stable regulation from low to high flow.
- Complete lockup in absence of gas flow, 100% bubble tight shutoff.
- Filter included in high capacity model.

*Spring is CSA outlet pressure certified **As approved by local codes and standards ***Brass vent limiter must be removed for outdoor installation

GOVAL LINE PRESSURE REGULATORS



STANDARD MODEL



Standard Model

Inlet Pressure Range: 3" W.C. to 15 PSIG
(for non-CSA Applications)

Inlet Pressure Range: 3" W.C. to 2 PSIG
(for CSA Applications)

MAIN FEATURES

- CSA 6.22A-2005 ANSI Z21.80A2005 Class I for outlet pressures up to 2 PSIG
- Integral Vent Limiter
- External Vent Limiter – no vent line required**
- Positive 100% bubble tight lock up
- Inlet and Outlet test ports
- 500:1 Turndown

SPECIFICATIONS

- Suitable for use with natural gas, LPG, and other non-corrosive, clean gas
- Inlet Pressure: 3" W.C. to 2 PSIG CSA approved
- Max. Inlet 15 PSIG for non-CSA applications
- Outlet pressure: 2" W.C. to 14" W.C. for CSA
Outlet pressure: 2" W.C. to 4.25 PSIG for non-CSA
- Temperature range: -40°F to 150°F
- Connections: 1/2"-2" NPT and 2 1/2" - 4" ANSI 150 flanged
- Maximum Emergency Inlet Exposure Pressure: 80 PSIG
- Suitable for indoor or outdoor installation***

VENT SIZE

- 1/4" NPT 1/2" – 1"
- 1/2" NPT 1 1/4" – 4"

OUTLET SPRING RANGE

- Green 2" W.C. to 5.1" W.C.*
- Red 2.75" W.C. to 7.87" W.C.*
- Black 6" W.C. to 14" W.C.*
- Yellow 9.8" W.C. to 27.5" W.C.
- Violet 23.6" W.C. to 59" W.C.
or 0.85 to 2.13 PSIG
- Orange 55" W.C. to 118" W.C.
or 2 to 4.26 PSIG

*Spring is CSA outlet pressure certified **As approved by local codes and standards ***Brass vent limiter must be removed for outdoor installation

GOVAL STANDARD MODEL

CAPACITY IN CFH FOR .60 SPECIFIC GRAVITY GAS WITH FILTER (CAPACITY WITHOUT FILTER IN BRACKETS)

Model #	Outlet Pressure Set Point	Operating Inlet Pressure		
		14" W.C.	1 PSIG	2 PSIG
F31061 1/2"	8" W.C.	252 (252)	454 (454)	646 (646)
	11" W.C.	179 (179)	420 (420)	648 (648)
F31061 3/4"	8" W.C.	315 (315)	568 (568)	808 (808)
	11" W.C.	224 (224)	526 (526)	811 (811)
F31063 1"	8" W.C.	405 (405)	730 (730)	1,039 (1,039)
	11" W.C.	288 (288)	676 (676)	1,042 (1,042)
F31060 1/2" High Capacity	8" W.C.	540 (608)	974 (1,096)	1,385 (1,558)
	11" W.C.	385 (433)	901 (1,014)	1,390 (1,564)
F31061 3/4" High Capacity	8" W.C.	698 (765)	1,258 (1,380)	1,789 (1,962)
	11" W.C.	497 (545)	1,164 (1,277)	1,796 (1,970)
F31062 1" High Capacity	8" W.C.	810 (900)	1,461 (1,624)	2,078 (2,309)
	11" W.C.	577 (642)	1,352 (1,503)	2,085 (2,317)
F31063 1 1/4"	8" W.C.	1,981 (2,454)	3,573 (4,426)	5,080 (6,292)
	11" W.C.	1,412 (1,749)	3,307 (4,096)	5,099 (6,315)
F31064 1 1/2"	8" W.C.	2,477 (2,567)	4,466 (4,629)	6,350 (6,581)
	11" W.C.	1,765 (1,829)	4,133 (4,284)	6,373 (6,605)
F31065 2"	8" W.C.	4,954 (5,404)	8,933 (9,745)	12,700 (13,855)
	11" W.C.	3,531 (3,852)	8,267 (9,019)	12,747 (13,906)
F31066 2 1/2"	8" W.C.	6,215 (6,665)	11,207 (12,019)	15,933 (17,088)
	11" W.C.	4,430 (4,751)	10,372 (11,123)	15,992 (17,151)
F31067 3"	8" W.C.	6,755 (8,106)	12,181 (14,618)	17,319 (20,783)
	11" W.C.	4,815 (5,778)	11,274 (13,528)	17,383 (20,859)
F31068 4"	8" W.C.	12,159 (14,186)	21,927 (25,581)	31,174 (36,370)
	11" W.C.	8,667 (10,112)	20,293 (23,675)	31,289 (36,504)

NOTE: Flow rates are actual stated recommended capacities, for optimal performance.

For additional sizing, visit linepressureregulator.com • 800.554.1036

GOVAL STANDARD MODEL - DIMENSIONS

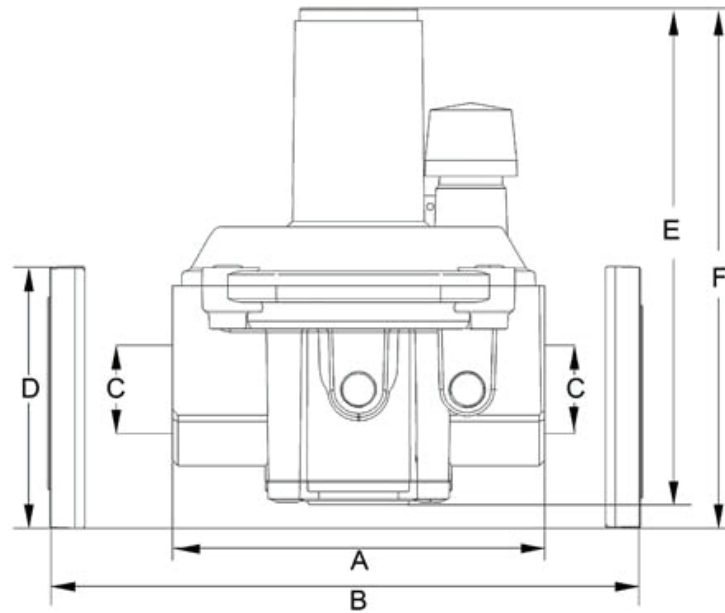

Model	Size	A	B	C	D	E	F	Weight (lbs)
F31061	1/2" NPT	4.29	-	1/2	-	5.59	-	1.54
F31062	3/4" NPT	4.29	-	3/4	-	5.59	-	1.54
F31063	1" NPT	4.29	-	1	-	5.59	-	1.54
F31160	1/2" NPT	5.43	-	1/2	-	6.89	-	2.75
F31161	3/4" NPT	5.28	-	3/4	-	6.89	-	2.75
F31162	1" NPT	5.28	-	1	-	6.89	-	2.75
F31163	1 1/4" NPT	7.64	-	1 1/4	-	10	-	7.5
F31164	1 1/2" NPT	7.64	-	1 1/2	-	10	-	7.5
F31165	2" NPT	9.29	-	2	-	12.44	13.74	12.34
F31166	2 1/2" FLANGED		16.9	3	ANSI 150	-	17.09	27.56
F31167	3" FLANGED		16.9	3	ANSI 150	-	17.09	27.56
F31168	4" FLANGED		16.9	4	ANSI 150	-	19.76	27.56

Residential and Commercial Applications



DIVAL 500



DIVAL 600



NORVAL



EQUIPMENT CONTROLS COMPANY

Ph: 800.554.1036

www.equipmentcontrols.com

