

GAS SAFETY CUT-OFF DEVICE

HBC/975



TECHNICAL MANUAL

MT052/E

**INSTALLATION START-UP AND
MAINTENANCE INSTRUCTION**

PRECAUTIONS

GENERAL PRECAUTIONS

- *The apparatus described in this manual is a device subject to pressure installed in systems under pressure;*
- *the apparatus in question is normally installed in systems for transporting flammable gases (natural gas, for example).*

PRECAUTIONS FOR THE OPERATORS

Before proceeding with installation, commissioning or maintenance, operators must:

- *examine the **safety provisions** applicable to the installation in which they must work;*
- *obtain the **authorisations** necessary for working when so required;*
- *use the necessary means of **individual protection** (helmet, goggles, etc.);*
- *ensure that the area in which they operate is fitted with the means of **collective protection** envisaged and with the necessary **safety indications**.*

HANDLING

*The handling of the apparatus and of its components must only be carried out after ensuring that the lifting gear is adequate for the **loads to lift** (lifting capacity and functionality). The apparatus must be handled using the **lifting points** provided on the apparatus itself. Motorised means must only be used by the persons in charge of them.*

INSTALLATION

*If the installation of the apparatus requires the application of **compression fittings** in the field, these must be installed following the **instructions of the manufacturer** of the fittings themselves. The choice of the fitting must be compatible with the use specified for the apparatus and with the specifications of the system when envisaged.*

COMMISSIONING

Commissioning must be carried out by adequately trained personnel.

During the commissioning activities, the personnel not strictly necessary must be ordered away and the no-go area must be properly signalled (signs, barriers, etc.). Check that the settings of the apparatus are those requested; if necessary, reset them to the required values in accordance with the procedures indicated in the manual.

When commissioning, the risks associated with any discharges into the atmosphere of flammable or noxious gases must be assessed.

In installations in natural gas distribution networks, the risk of the formation of explosive mixtures (gas/air) inside the piping must be considered.

PRECAUTIONS

Packing for transportation of equipment is designed and shaped to avoid damage to any part during handling activities. After packing is open, check that no damage occurred to equipment. If damage occurred inform manufacturer and keep packing for any verification.

CONFORMITY TO DIRECTIVE 97/23/EC (PED)

Shut off valve HBC 975 with pressure switches for overpressure and underpressure may be employed as pressure accessory or safety accessory according to directive 97/23/EC.

Conformity to Directive 97/23/EC and CE marking of valve and relevant accessory requires installation on system with minimum requirements according to:

EN 12286- EN 12279

Pressure valve does not require any safety accessory installed upstream for protection against overpressure compared with design pressure PS, when reducing station installed upstream is sized for a max downstream incidental pressure $MIPd \leq 1,1 PS$.

Valve, when installed on a reducing station must be installed at least according to requirements of standard EN 12186 and EN 12279.

All venting connection shall be connected as required by above mentioned standard.

installation. If equipment is employed as safety accessory, internal tightness shall be verified at a pressure value of 1,1XPS.

Both verifications are essential to maintain CE marking.

Periodical inspection and maintenance shall be carried out according to standard and laws in force (kind and period).

Before commissioning of equipment after maintenance, external tightness shall be verified at a pressure value equal to value available on

1. DESCRIPTION	5
1.1 Main features	5
1.2 Fields of application and operation	5
1.3 Operation	6
1.3 Settings	7
2. INSTALLATION	9
2.1 General	9
3. COMMISSIONING	11
3.1 General	11
3.2 Checking the setting	13
3.3 Commissioning	14
4. ACCESSORIES	14
5. TROUBLE-SHOOTING	15
6. MAINTENANCE	16
6.1 General	16
6.2 Disassembly	16
7. COMPONENTS AND SPARE PARTS LIST	19

EDITION 2/2002

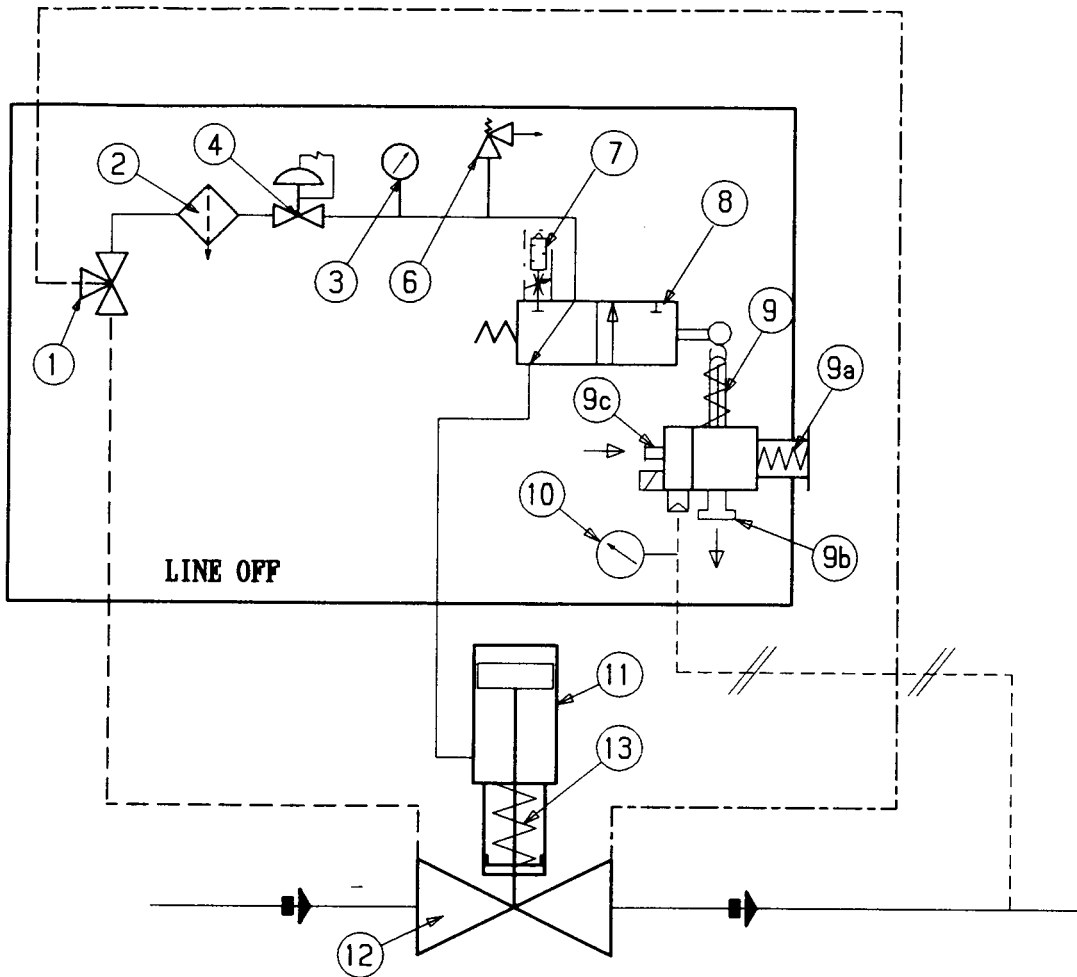

DIAGRAM SHOWS ACTUATOR IN OPEN POSITION

---//--- SENSING LINE _____ PNEUMATIC CONNECTION
 - - - - - PNEUMATIC SUPPLY - - - - - BY PASS LINE

ITEM	DESCRIPTION		
1)	BY-PASS 3 WAY VALVE	9a)	SETTING SPRING
2)	FILTER CF 14 R 1/4	9b)	RELATCHING KNOB
3)	PRESSURE GAUGE	9c)	BUTON OF MANUAL TRIP
4)	PRESSURE REGULATOR R 91	10)	PRESURE GAUGE
6)	RELIEF VALVE	11)	SINGLE ACTING ACTUATOR
7)	DUMPER THROTTLE (CLOSE)	12)	CUT-OF VALVE
8)	3/2 PNEUMATIC VALVE	13)	VALVE SPRING
9)	TRIPPING UNIT SH 11-90		

Fig. 1

1. DESCRIPTION

The HBC 975 gas safety cut-off device is an apparatus which blocks the flow of gas if the controlled pressure reaches the set-point for its intervention, or if actuated manually.

1.1 Main features

The valve is suitable for medium and high pressures.

The main features of this valve are:

- Gas cut-off in both directions
- Balanced valve obturator
- Indirect, self-fed, pneumatic actuation
- Intervention for minimum and/or maximum pressure
- Adjustable closing speed from 0.5 to 2 sec.
- Local close button
- Incorporated bypass
- Manual reset only
- Easy maintenance without removing body
- Highly reliable internal parts
- Possibility of build-in on Reflux and Aperflux regulators

1.2 Fields of application and operation

- Non-corrosive filtered gas
- Design pressure : 100 bar
- Working temperature: from -10° to +60°C (-20°+60°C on request)
- SH 11 90 control devices
- Intervention for maximum pressure: 1 – 85 bar
- Intervention for minimum pressure: 0.4 – 75 bar

1.3 Operation

The cut-off device consists principally of the following parts

- on/off valve (12)
- single action pneumatic actuator
- line-off device

When there is no pressure, the valve obturator is held in the closed position by the spring, pos. (13), and rests on the valve seat. The seal is guaranteed by the contact between the obturator and the valve seat. The control pressure is obtained by taking off gas at pressure P_e directly upstream from the valve. The gas passes through the valve (1) (which can deviate the pressure towards the downstream piping through a bypass line) and, appropriately filtered by the filter (2), enters the pressure regulator(4), the purpose of which is to stabilize the control pressure to the valve (4 bar); this can be checked on the pressure gauge(3). The stabilized gas enters the pneumatic valve 3/2 (8) and then passes to the actuator(11). When the actuator is filled, the valve opens.

1.3 Settings
Setting springs

table TT 984

TRIPPING UNIT TYPE SH 1190 MOD. 103											
SPRING CHARACTERISTICS							SET POINT RANGE IN bar				
POS.	CODICE	d	De	Lo	i	it	FOR INCREASING PRESSURE				
1	2701142	3.2	35	60	5.5	8	0.8	1	1.4	1.45	
2	2701260	3.5			5.5	7.5	1.2	1.3	2.1	2.2	
3	2701530	4			5	7	1.8	2	3.7	3.8	
4	2701790	4.5			4.5	6.5	3.5	3.6	6.8	7	
5	2702070	5			5	7	4.8	5	7.8	8	
6	2702280	5.5			4.5	6.5	6.8	7.2	11	11.5	
							FOR DECREASING PRESSURE				
7	2700513	2	15	40	8.5	10.5	0.3	0.4	1	1.1	
8	2700713	2.3			8.5	10.5	0.9	1	1.9	2	
9	2700750	2.5			6.5	8.25	1.7	1.8	2.8	3	
10	2700985	3			6	8	2.6	2.7	6.8	7	

TRIPPING UNIT TYPE SH 1190 MOD. 104											
SPRING CHARACTERISTICS							SET POINT RANGE IN bar				
POS.	CODICE	d	De	Lo	i	it	FOR INCREASING PRESSURE				
1	2701790	4.5	35	60	4.5	6.5	9	10	17	18	
2	2702070	5			5	7	13	14	19	20	
3	2702280	5.5			4.5	6.5	17	17.2	31.5	33	
							FOR DECREASING PRESSURE				
5	2700750	2.5	15	40	6.5	8.25	4.25	4.5	6.8	7	
6	2700985	3			6	8	6.7	6.8	20.6	21	



CAMPO DI TARATURA CONSIGLIATO
Suggested set point range

d -DIAMETRO FILO
dia wire

De -DIAMETRO ESTERNO
external dia

Lo -LUNGHEZZA
length

i -SPIRE UTILI
active coils

it -SPIRE TOTALI
total coils

table TT 985

TRIPPING UNIT TYPE SH 1190 MOD. 105											
SPRING CHARACTERISTICS							SET POINT RANGE IN bar				
POS.	CODICE	d	De	Lo	i	it	FOR INCREASING PRESSURE				
1	2701790	4.5	35	60	4.5	6.5	17.5	25	41	43	
2	2702070	5			5	7	32	34	48	51	
3	2702280	5.5			4.5	6.5	41	43	76	78	
4	2702290 *	5.5	35	100	8.25	10.25		55	58	85	90
							FOR DECREASING PRESSURE				
5	2700750	2.5	15	40	6.5	8.25	10	11	16.5	17	
6	2700985	3			6	8	16.2	16.5	50	51	
7	2701182 *	3.4			6	8	42	45	75	78	

TRIPPING UNIT TYPE SH 1190 MOD. 105											
SPRING CHARACTERISTICS							Set point range in psig				
POS.	CODICE	d	De	Lo	i	it	FOR INCREASING PRESSURE				
1	2701790	4.5	35	60	4.5	6.5	250	365	600	630	
2	2702070	5			460	490	700	740			
3	2702280	5.5			4.5	6.5	600	630	1100	1130	
4	2702290 *	5.5	35	100	8.25	10.25		802	850	1240	1313
							FOR DECREASING PRESSURE				
5	2700750	2.5	15	40	6.5	8.25	150	158	240	245	
6	2700985	3			235	240	730	738			
7	2701182 *	3.4			6	8	613	657	1095	1138	

* FOR SH 1190 MOD. 105/92

CAMPO DI TARATURA CONSIGLIATO
 Suggested set point range

 d -DIAMETRO FILO
 dia wire

 De-DIAMETRO ESTERNO
 external dia

 Lo -LUNGHEZZA
 lenght

 i-SPIRE UTILI
 active coils

 it-SPIRE TOTALI
 total coils

2. INSTALLATION

2.1 General

The HBC 975 cut-off device is always supplied complete with nipple for the sensing line. Before installing the valve you must ensure that:

- the valve can be inserted in the space provided and that there is enough room for later maintenance operations
- the piping upstream and downstream is at the same level and capable of supporting the weight of the valve; if it is not, fit appropriate supports
- the inlet/outlet flanges on the piping are perfectly parallel
- the interior of the mouths of the valve are clean and the valve has not suffered damage during transport
- the upstream piping as far as the filter has been cleaned so as to expel residual impurities such as welding slag, sand, paint residues, water, etc.

When the above controls have been carried out, the valve can be fitted in line, making sure that the body is oriented so that the flow is in the direction shown by the arrow impressed on the body itself.

For proper regulation, it is indispensable for the downstream sensing line to be connected to a rectilinear stretch of the downstream piping itself with a length in accordance with the table and with a maximum gas speed at the take-off point not exceeding 30 m/sec.

The valve closing pressure switch command is generated by comparing the pressure in the line, which can be read on the pressure gauge (10) and the setting springs (minimum and/or maximum) of the SH 11-90 pressure switch device. When the ratio of the comparison deviates from the maximum value (or lower in the case of minimum setting) the pressure switch device moves the pneumatic control lever which discharges the gas from the obturator control chamber through the dumper (7). The spring (13) closes the valve (12). The valve can also be closed by mechanical movement by pressing the button (9B).

The valve can only be reset manually by means of the reset pomel of the SH 11-90 valve. To prevent the accumulation of impurities and condensate in the sensing line, it is recommended that:

- the sensing line should always descend towards the nipple on the downstream piping with a slope of about 5 –10%
- the downstream piping nipple must always be welded to the top part of the piping itself.

The most common types of installation for the HBC 975 cut-off device are shown in figures 2 and 3.

Figure 2 shows installation in a pressure regulation line; figure 3 shows installation on a generic trunk.

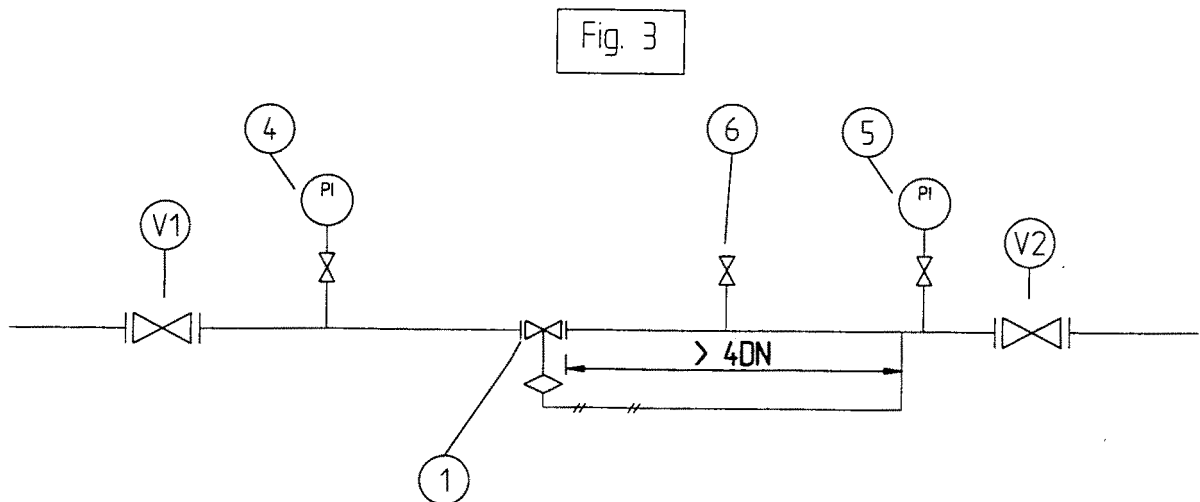
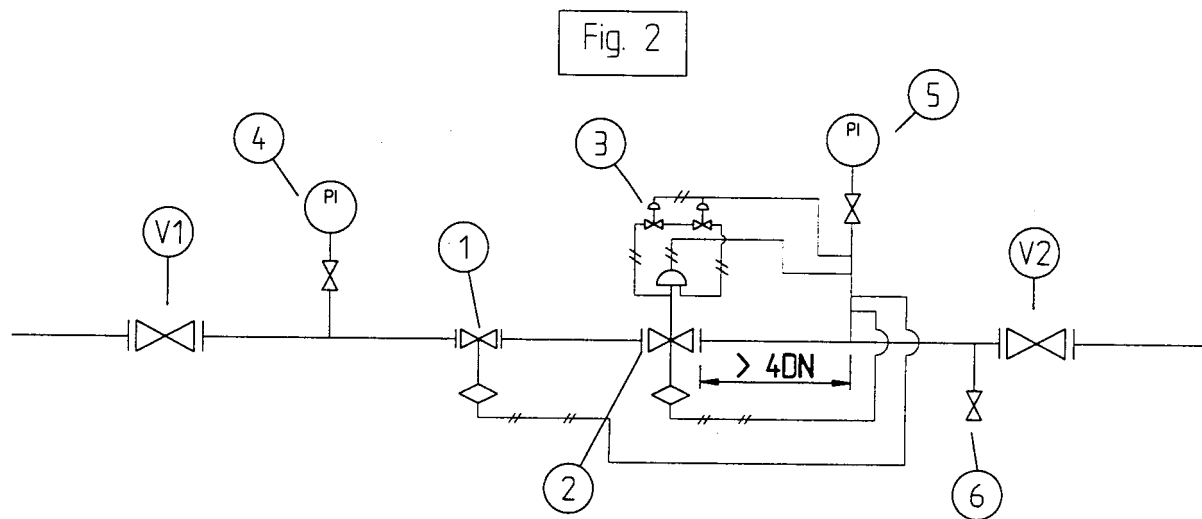

- V1 UPSTREAM ON-OFF VALVE
- 1 GAS SAFETY CUT-OFF DEVICE
- 2 PRESSURE REGULATION WITH BUILT-IN CUT-OFF DEVICE
- 3 PILOT REGULATOR
- 4 UPSTREAM PRESSURE GAUGE
- 5 DOWNSTREAM PRESSURE GAUGE
- 6 DOWNSTREAM BLEED VALVE
- V2 DOWNSTREAM ON-OFF VALVE

3. COMMISSIONING

3.1 General

After installation, check that:

- the inlet/outlet on/off valves and the bleed cock are closed
- the cut-off device is closed.

The open-closed situation can be seen from the position of the open-closed indicator on the head of the pressure switch control.

The cut-off device is normally supplied already set at the required value but, for safety reasons, setting should be repeated in accordance with the procedure illustrated in the paragraphs which follow.

ATTENTION: check that the conditions of use comply with the characteristics of the cut-off device before commissioning. These characteristics are shown by the symbols on the plates applied on every apparatus. Table 1 on page 12 lists the symbols used and their meanings.

Consult table TT984-TT985 for the recommended set-point.

- external tightness is guaranteed if no visible leakage when a foam medium is applied on the element under pressure
- the internal tightness of an element which separates two chambers under different pressures is guaranteed when the pressure in the closed chamber with the lower pressure remains stable for a period of no less than 15 minutes taking account of the temperature variations.

table 1

Some symbols employed on these name plates are described here below

- Pemx = max inlet working pressure
- Who = intervention range of tripping unit in the event of overpressure. It may be obtained by using the set point springs shown in the applicable tables TT984- TT985
- Wao = intervention range of tripping unit in the event of overpressure. It may be obtained by means of the set point spring installed by P.Fiorentini during the testing
- Whu = intervention range of tripping unit in the event of underpressure. It may be obtained by changing the set point springs as shown in the applicable tables TT984- TT985
- Wau = intervention range of tripping unit in the event of underpressure. It may be obtained by means of the set point springs installed by P.Fiorentini during the testing.

3.2 Checking the setting

Check as follows that the set-point of the cut-off device has the value desired:

- separately connect the control head to a controlled auxiliary pressure
- press the provided button to trip the cut-off device to the closed position
- slowly open the on/off valve V1 upstream from the cut-off device with consequent pressurization of the line upstream from the cut-off device
- position the three-way valve (1) in the bypass position and pressurize the line downstream from the cut-off device
- ensure that the pressures above and below the valve are balanced
- actuate the pressure switch reset knob (9B)
- position the 3-way valve (1) in the working position
- control the cut-off device opening through the provided indicator
- stabilize the value of the auxiliary pressure at a lower value than the maximum pressure intervention point or between the maximum and minimum values when setting up for both types of intervention
- reset the cut-off device device using the provided knob and:
 - ♣ **for safety devices which intervene for upper pressure:** slowly increase the auxiliary pressure and check the trip pressure value; if necessary, increase the trip pressure value by turning the adjustment ring clockwise, or anticlockwise to reduce the intervention value.
 - ♣ **for safety devices for upper and lower:** slowly increase the auxiliary pressure and record the trip pressure value. Restore the auxiliary pressure to the initial value, and carry out the cut-off device reset operation. Check intervention for pressure reduction by slowly reducing the auxiliary pressure.

3.3 Commissioning

- Trip the cut-off device mechanically to the closed position by pressing the provided button.
- Slowly open the on/off valve V1 upstream from the cut-off device with consequent pressurization of the line upstream from the valve.
- Operating manually, position the 3-way valve in the bypass position and slowly pressurize the line downstream from the cut-off device and control the flanged and threaded seals in the section
- Ensure that the pressures upstream and downstream the valve are in equilibrium

- Actuate the reset knob (9B) of the pressure switch with consequent activation of the SH 11-90 pneumatic device.
- Turn the lever of the 3-way valve (1) slowly to the work position.
- Control the opening of the cut-off device through the provided indicator

4. ACCESSORIES

The following can be applied to the valve, on request:

- valve and/or closed signalling microswitch
- emergency system with remote control

The system can also be built-in on Reflux and Aperflux regulators.

5. TROUBLE-SHOOTING

PROBLEM	POSSIBLE CAUSES	REMEDY
The cut-off device obturator does not close	<p>Clogging of discharge nozzle of pneumatic valve 3/2.</p> <p>Rupture of the diaphragm (4) or O-ring (4) of the measuring head</p>	<p>Clean</p> <p>Replace</p>
Leakage from the cut-off device obturator	<p>Obturator seal (7) deteriorated.</p> <p>O-rings (87) (88) deteriorated</p> <p>Obturator seat (71) worn or scratched</p>	<p>Replace</p> <p>Replace</p> <p>Grind or Replace</p>
Incorrect trip pressure	<p>Incorrect setting of max and/or min spring</p> <p>Friction</p> <p>Leakage from GACO ring of the pneumatic control</p>	<p>Reset by means of the adjustment ring</p> <p>Clean</p> <p>Replace</p>
Not possible to reset	<p>The reason for increase or decrease of pressure downstream persists</p> <p>Broken linkage</p> <p>No pressure after pneumatic resetting</p>	<p>Checks the causes</p> <p>Replace the SH 11-90 pressure switch</p> <p>Replace filter cartridge</p>

6. MAINTENANCE

6.1 General

Before any maintenance operation, discharge the pressure as follows:

- a) close the upstream on/off valve V1
- b) close the downstream on/off valve V2
- c) check that the cut-off device is open
- d) very slowly discharge the pressure through the bleed cock to the atmosphere (6)

In the event of intervention for minimum pressure, discharge the pressure upstream from the valve by turning the 3-way cock (1) to the bypass position.

6.2 Disassembly

Before starting the disassembly operations, it is necessary to check that:

- the valve has been cut off upstream and downstream and that the pressure between the two on-off valves has been discharged
- you have a set of spanners as specified in the table
- you have the recommended set of spare parts

Depending on the type of problem which has occurred, maintenance may involve:

- a) the on/off valve
- b) the single action pneumatic actuator
- c) the line-off device

a) On-off valve

It is possible to remove the cut-off device valve without disconnecting the body from the piping.

- disconnect all the feed and sensing line connections, by unscrewing all the conical seal connections
- slacken the fixing screw of the LINE OFF system support bracket
- slacken the fixing screw pos. (32) and remove the cut-off device device
- slacken the nuts pos. (33) fixing the obturator pos. (71) to the rod pos.(6)
- remove the obturator pos.(71)
- relax completely the spring pos. (80) unscrewing the locknut pos.(9)
- remove the spring pos.(80)
- slacken the fixing screws pos. (86) and remove the obturator guide pos.(72)
- slacken the fixing screws pos. (89) of the lock ring pos. (8) of the reinforced gasket

pos.(7)

- remove the lock ring pos. (8) and the reinforced gasket pos.(7)
- control and clean the metal parts
- carefully control the state of the obturator valve seat
- replace all the components in the spare parts kit

Single action pneumatic actuator

- unscrew the nut pos. (60) and remove the stroke reference ring pos. (59)
- slacken the fixing nuts pos. (67) and remove the flange pos. (74)and the plating pos.(75)
- remove the balancing piston pos.(15)
- keeping the spacer pos. (69) firm, unscrew and remove the balancing rod guide pos. (11)
remove the piston pos. (65) and the spacers pos. (69) and (19)
- slacken the fixing screws pos.(27)
- separate the flange pos. (73) from the cover pos. (70)
- remove the rod guide pos. (20) from the cover pos. (70)
- replace all the components in the spare parts kit

b) Line-off device

Filter

- -slacken the cup pos. (1) and remove from cover pos. (2)
- slacken the screw pos. (5)and remove the filter cartridge pos.(4)
- replace all the components in the spare parts kit

R91 pressure regulator

- slacken the locknut pos.(17)
- turn the adjusting screw pos. (15) anticlockwise to slacken to the end of its stroke
- slacken the screws pos. (23) and remove the sleeve pos.(14), the spring support pos.(16), the spring pos. (21) and the diaphragm holder assembly
- unscrew the locknut pos. (22) from the diaphragm support pos. (11) and remove the spring support pos. (13) and the diaphragm pos.(10)
- unscrew the plug pos. (1) and remove the spring support pos.(6), the spring pos.(20), the lock ring pos.(7), the obturator pos. (8) and the reinforced gasket pos.(3)

- replace all the components in the spare parts kit

VS/FI bleed valve

- unscrew the plug pos.(3), discharge the spring pos. (4) and remove the obturator pos.(2)
- carefully check the state of the valve seat
- replace all the components in the spare parts kit

Pressure switch device type SH1190 type 104

- disconnect the signal take-off
- slacken the fixing screws pos. (43)
- remove the cover pos. (2)
- replace all the components in the spare parts kit

NOTE: After cut-off device intervention, close the on/off valves upstream and downstream and discharge the pressure. The cut-off device must never be actuated before remedying the problem that caused it to trip.

7. COMPONENTS AND SPARE PARTS LIST

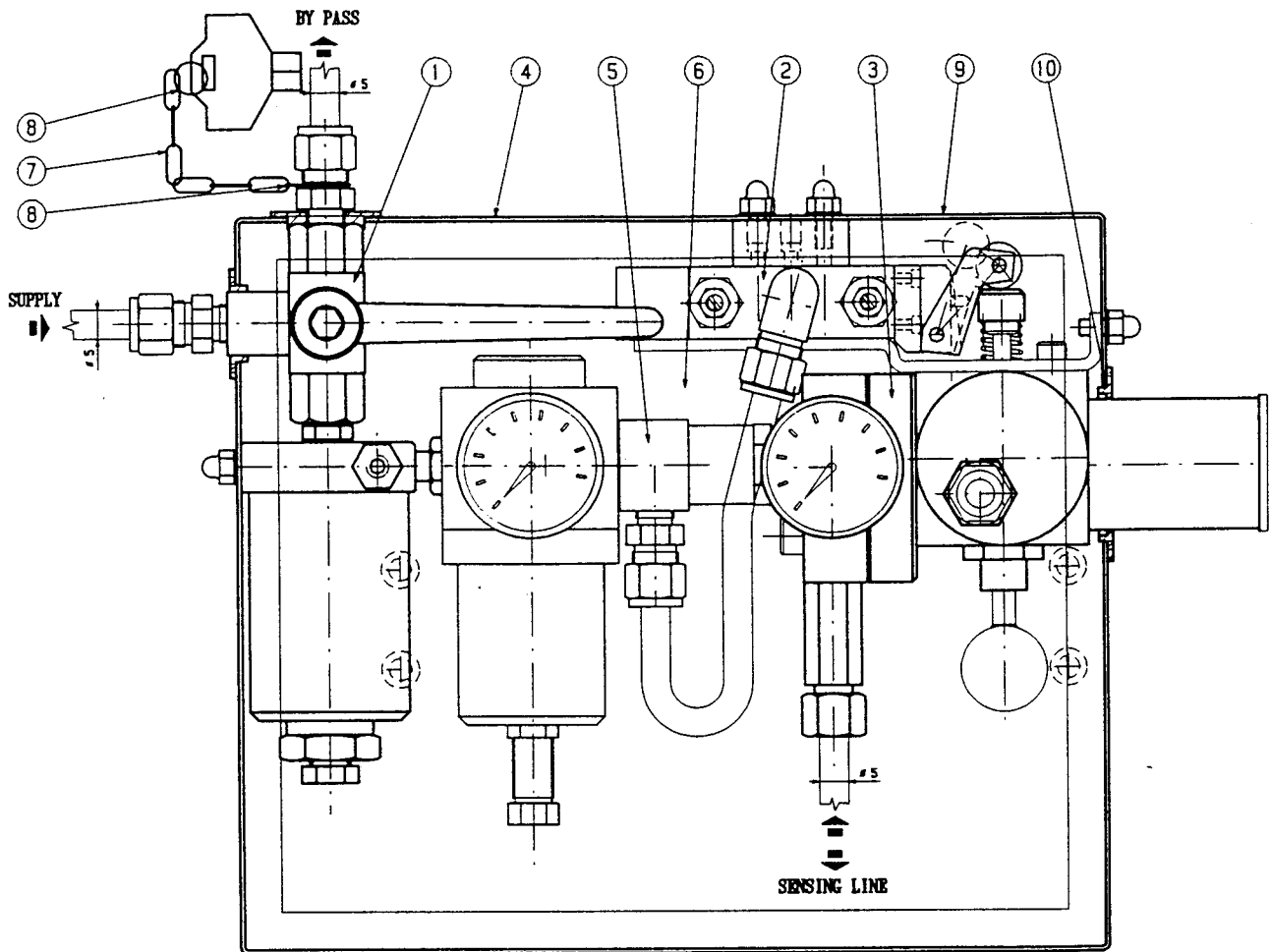

SLAM-SHUT CONTROLLER TYPE 104 DN 1/4" PE=85 BAR

Components and materials list

Rubber and spare parts components

Item	Code	Description	Qt.	Material
1	6189032	Pressure reducing group	1	See relevant list
2	6189065	Pressure distribution group	1	"
3	6189094	Trip mechanism SH 11 90 type 104	1	"
4	6760027	Slam-shut controller box	1	Carbon steel
5	6999057	Connection pipe	1	Stainless steel
6	6999066	Front panel	1	Alluminium
7	2180500	Chain	1	Carbon steel
8	2180502	Rings	2	"
9	2420300	Cup	4	Plastic
10	6999071	Cup	1	"

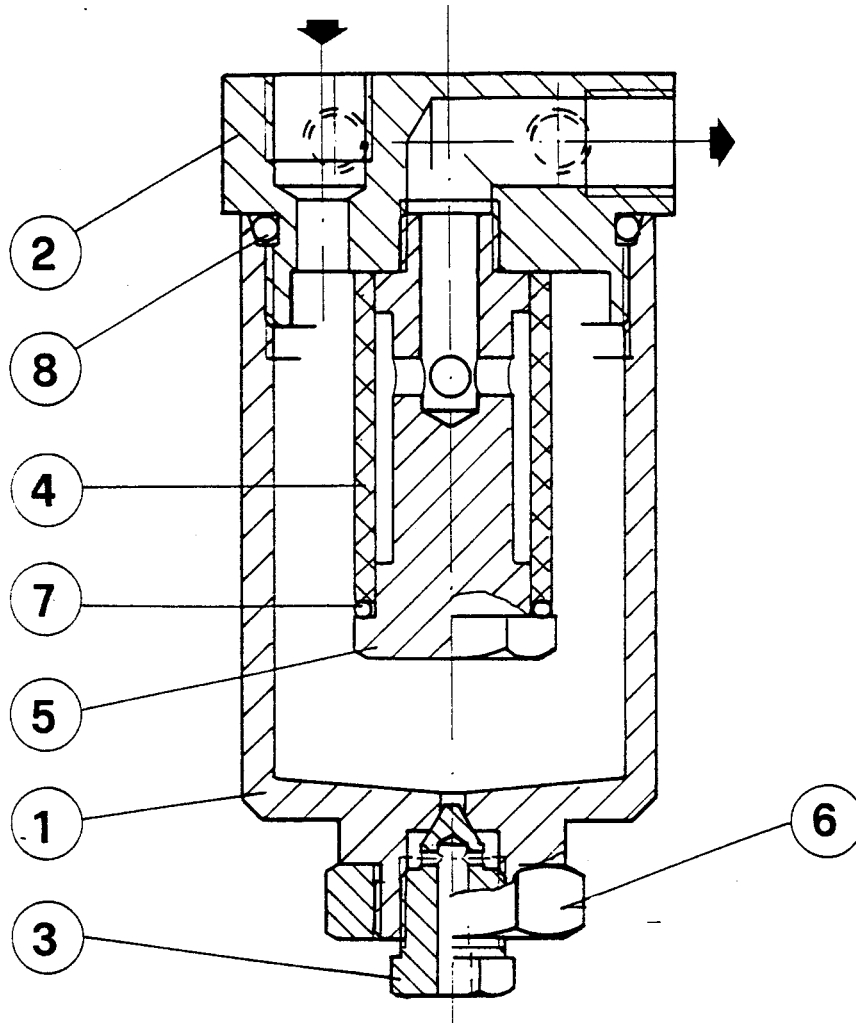

Filter (7089068)

Components and materials list

Rubber and spare parts components

Item	Code	Description	Qt.	Material
1	7425284	Cup	1	Carbon steel
2	7468028	Cover	1	"
3	7849007	Vent screw	1	"
# 4	7552038	Cartridge	1	Bronze
5	7703943	Lock screw	1	Carbon steel
6	2320419	Nut M20 x 1,5 UNI 5589 - 6s	1	"
# 7	2620104	O.Ring 152 Nitril 70SH	1	Nitril rubber
# 8	2620094	O.Ring 147 Nitril 70SH	1	Nitril rubber

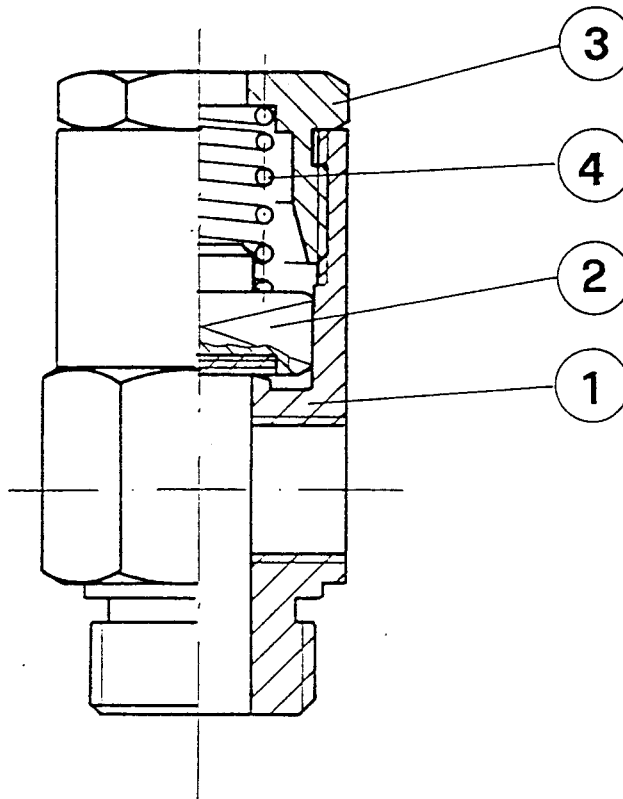

Relief valve VS/FI R 3/8"-R 1/4" (7389070)

Components and materials list

Rubber and spare parts components

Item	Code	Description	Qt.	Material
1	7481432	Body	1	Stainless steel
# 2	7200363	Obturator valve	1	Rubber/steel
3	7841369	Plug	1	Stainless steel
4	2700463	Spring D. 1,7 De. 15 L. 35 IT. 7 1/2	1	Carbon steel

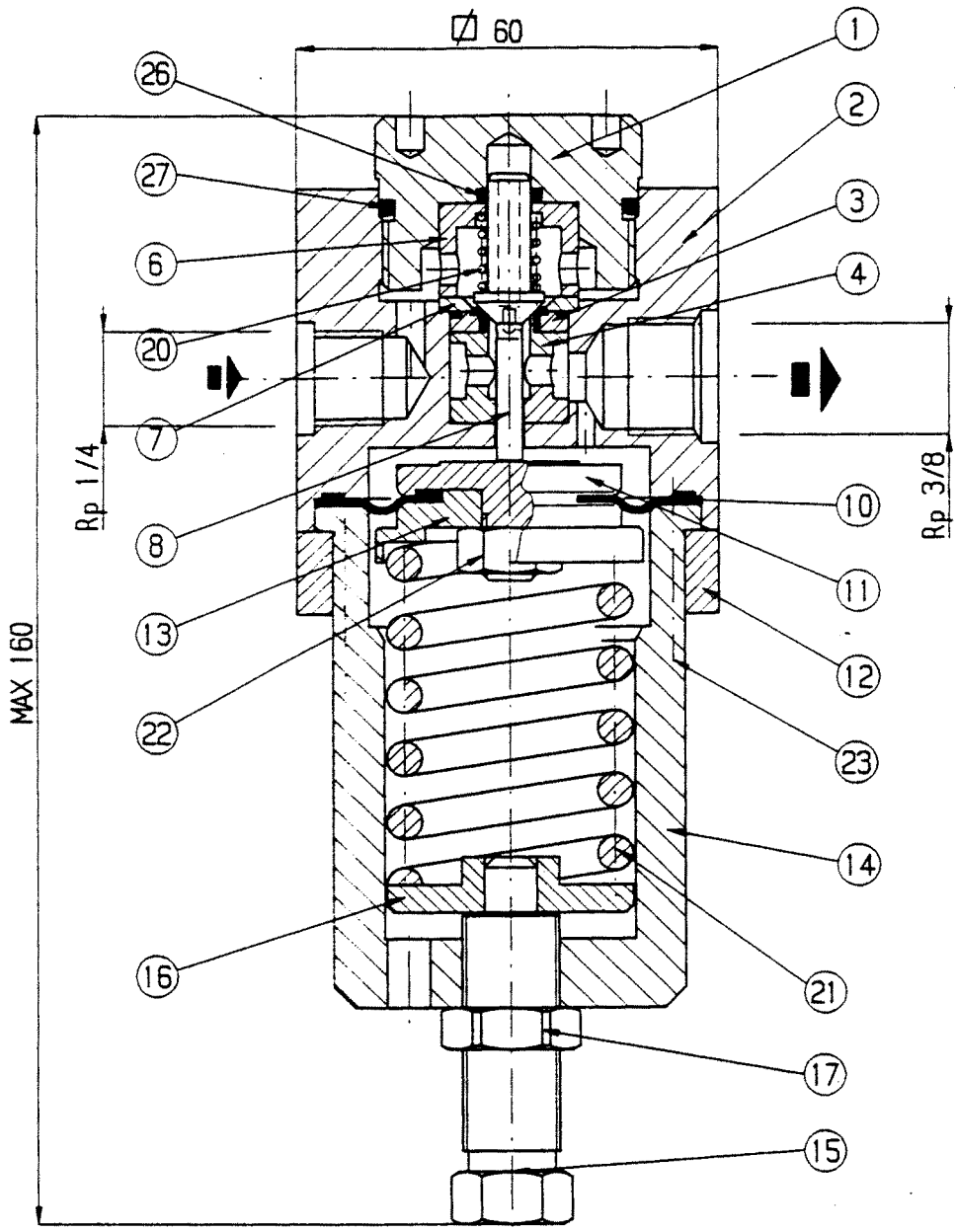

Pressure Regulator - R 91 (7180485)

Components and materials list

Rubber and spare parts components

Item	Code	Description	Qt.	Material
1	7841332	Plug	1	Carbon steel
2	7481375	Body	1	"
# 3	7121013	Reinforced gasket	1	Rubber/steel
4	7818006	Gasket holder	1	Brass
5	7625001	Obturator valve guide	1	Brass
6	7828009	Spring holder	1	Carbon steel
7	7407003	Lock ring	1	Brass
8	7689019	Obturator valve	1	Stainless steel
# 10	7656027	Diaphragm	1	Canvas rubber
11	7823010	Diaphragm holder	1	Brass
12	7800026	Frame	1	Carbon steel
13	7828019	Spring holder	1	Brass
14	7650312	Liner	1	Carbon steel
# 15	7905257	Setting screw	1	Brass
16	7828031	Spring holder	1	Carbon steel
17	7510026	Lock nut	1	Brass
20	2700308	Spring D = 1,1 De = 9 L = 20 it.6,5	1	Carbon steel
21	2702065	Spring D = 5 De = 35 L = 50 it.6	1	"
22	2321208	Nut M 8 - UNI 5588 - 6s	1	"
23	2301135	Screw M12 x 40 UNI 5739 - 8.8	1	"
# 26	2624510	O.Ring 2025 (47-071)	1	Nitril rubber
# 27	2620350	O.Ring 3125 Nitril 70SH	1	"

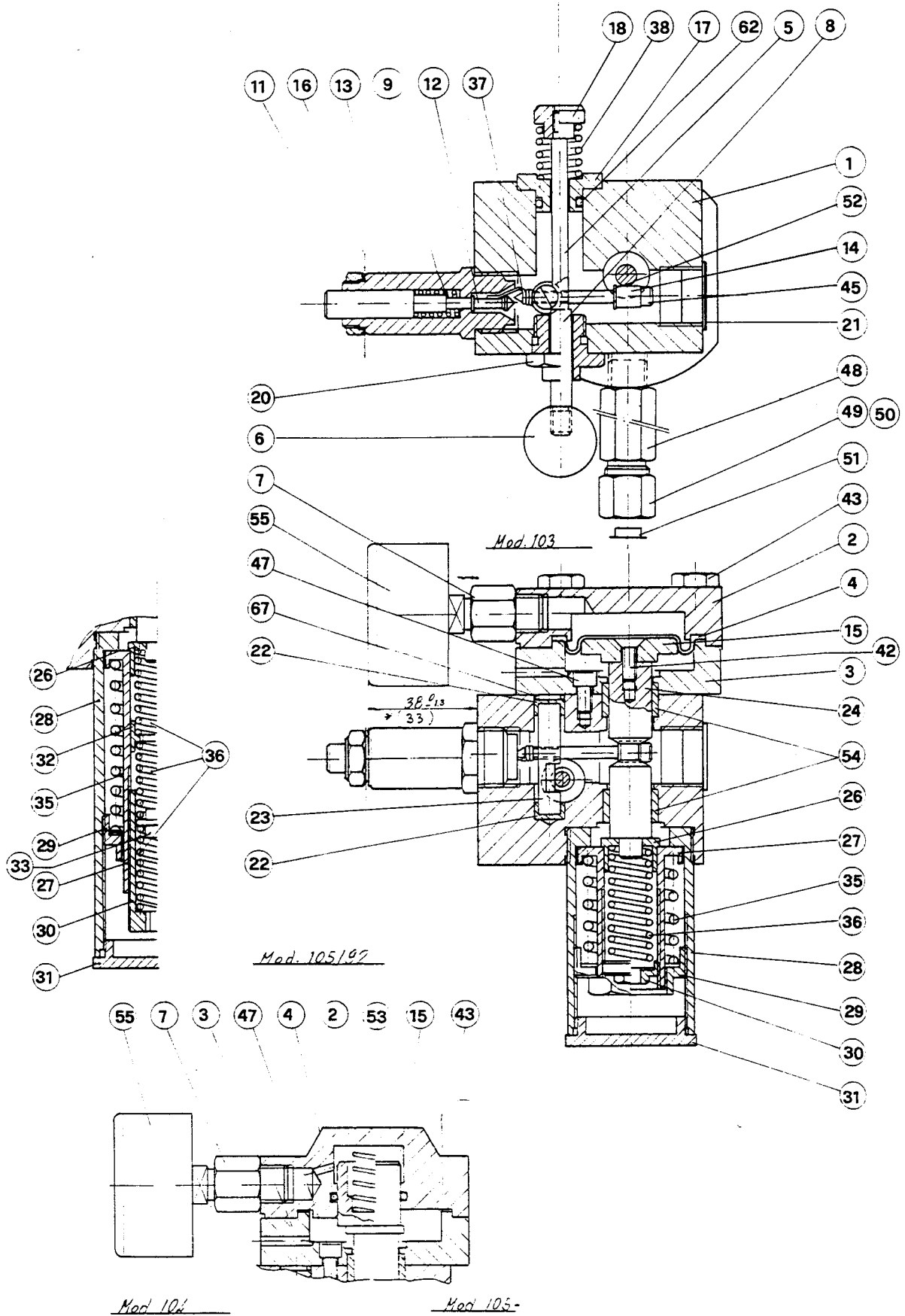

TRIP MECHANISM SH 11 90 TYPE 104

Components and materials list

Rubber and spare parts components

Item	Code	Description	Qt.	Material
1	7481565	Body	1	Carbon steel
2	7468044	Cover	1	"
3	7555051	Flange	1	"
# 4	2624566	O.Ring 3043 Nitril 70SH	1	Nitril rubber
5	7805012	Spindle	1	Stainless steel
6	2310552	Knob	1	Plastic
7	6730039	Connector	1	Carbon steel
8	7435023	Bush for spindle	1	Stainless steel
9	2700260	Spring D = 1 De = 9 L = 22 it.9,5	1	Carbon steel
11	7510026	Nut	1	Brass
12	6999064	Buttom rod	1	Stainless steel
13	7805009	Buttom	1	"
14	7430033	Bush	1	Carbon steel
15	7710038	Piston	1	Stainless steel
16	7625027	Guide for buttom	1	Brass
17	7613015	Upper guide for trip element	1	"
18	6999063	Trip nut	1	Carbon steel
20	7625022	Bottom guide for trip element	1	Brass
21	2420052	Plug	1	Plastic
22	7430008	Bush	2	Brass
23	7703043	Rod	1	Stainless steel
24	7413012	Spindle	1	"
26	7828016	Spring holder	1	Brass
27	7828029	Spring holder	1	"
28	7650340	Liner	1	Carbon steel
29	7590820	Spring adjustement nut	1	Brass
30	7590304	Spring adjustement nut	1	"
31	7841041	Plug	1	Alluminium
35	T.T.984	Over pressure setting spring	1	Carbon steel
36	T.T.984	Under pressure setting spring	1	"
37	7999008	Spring for trip element	1	"
38	2700463	Spring D = 1,7 De = 15 L = 35 it.7,5	1	"
43	2301075	Screw M8 x 35 UNI 5737 - 8.8	4	"
45	7910029	Screw	1	"
47	2300075	Screw M5 x 16 UNI 5931 - 8.8	3	"
48	7730008	Connector	1	"
49	2410056	Nut for connector	1	"
50	2410087	Ferrule for connector	1	"
51	2420065	Plug	1	Plastic
53	2700295	Spring D = 1 De = 15 L = 35 it.9,75	2	Carbon steel
54	2360203	Bush	1	Stainless steel
55	3504140	Pressure gauge D = 50 R1/8" (0-40 Bar)	1	
# 62	2620030	O.Ring 115 Nitril 70SH	1	Nitril rubber
# 67	2620014	O.Ring 2031 Nitril 70SH	1	"
# 70	2620014	O.Ring 2031 Nitril 70SH	1	"

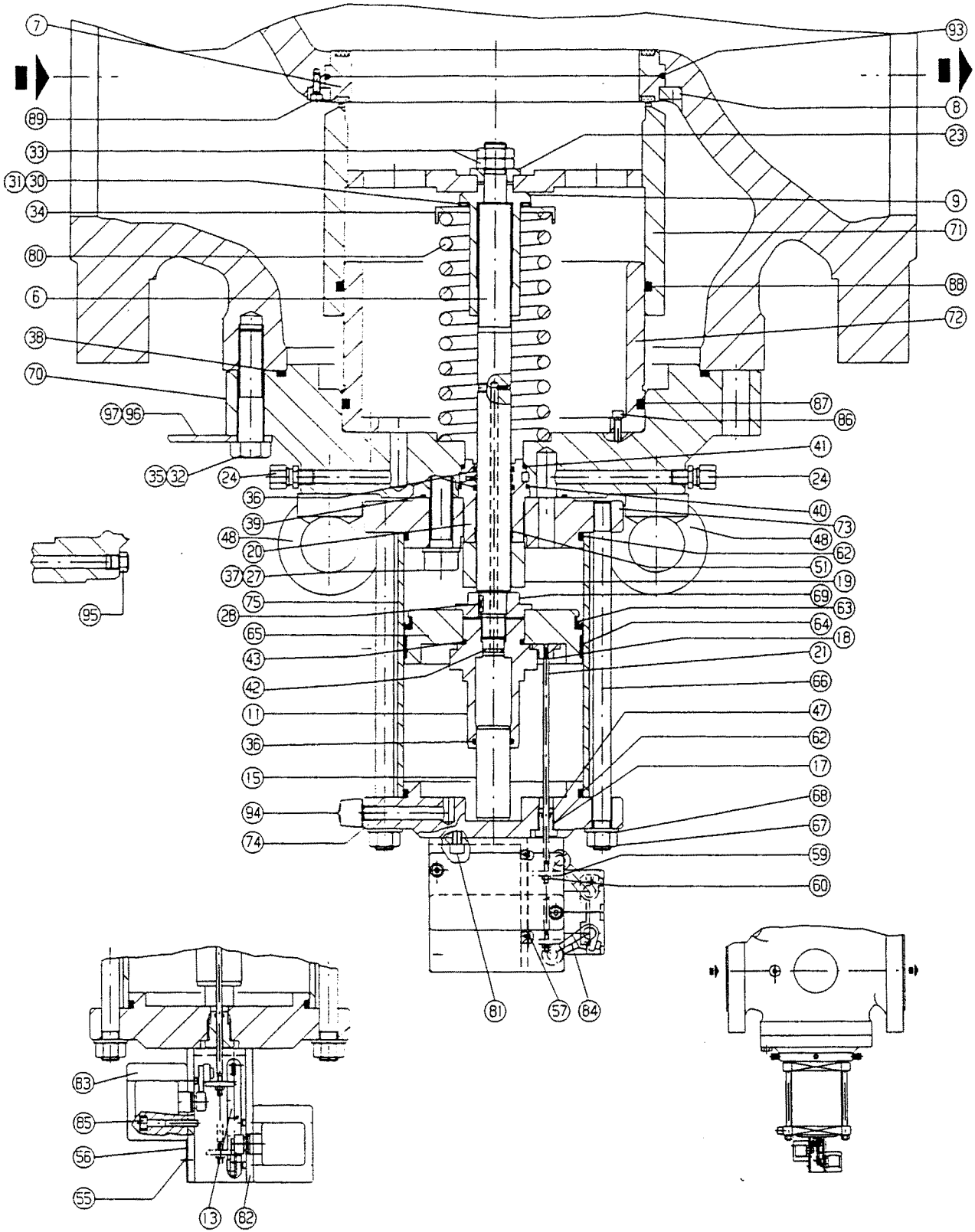

SLAM-SHUT VBC/975 DN 6"

Components and materials list

Rubber and spare parts components

Item	Code	Description	Qt.	Material
6	7805502	Stem	1	AISI 420
# 7	7121458	Valve seat	1	Metal and rubber
8	7407976	Metafic fasten ring	1	Carbon steel
9	7510678	Fasten nut	1	Brass
11	7626437	Guide for balancing stem	1	Carbon steel
13	7857024	Stroke indicator label	1	Alluminium
15	7710277	Balancing stem	1	AISI 420
17	XPR98816	Guide for travel indicator rod	1	Brass
18	7718047	Nut for travel indicator rod	1	Carbon steel
19	7535317	Spacer	1	Alluminium
20	7613831	Guide for stem	1	Brass
21	XPR98813	Travel indicator rod	1	AISI 303
23	7739590	Washer	1	Carbon steel
24	7730008	Male connector	1	Stainless steel
25	XPR9889	Couplement ring	1	Carbon steel
26	2410056	Nut for male connector	1	Stainless steel
27	2301210	Screw M14 x 50 UNI 5737 - 8.8	4	Carbon steel
28	2326048	Feather key	1	"
29	2410087	Ferrule		
30	2600555	Bearing	1	"
31	2600551	Bearing washer	2	"
32	2301365	Screw M20 x 60 UNI 5737 - 8.8	18	"
33	2320827	Nut M18 x 1,5 UNI 5589 6s	2	"
34	7828613	Spring holder	1	"
35	2301380	Screw M20 x 70 UNI 5737 - 8.8	2	"
# 36	2622066	O.Ring 4100 Viton 90SH	3	Flourocarbon rubber
37	2325314	Lock washer	4	Carbon steel
# 38	2620444	O.Ring 4925 Nitril 70SH	1	Nitril rubber
# 39	2620396	O.Ring 4362 Nitril 70SH	2	"
# 40	2620104	O.Ring 152 Nitril 70SH	1	"
# 41	2620085	O.Ring 4162 Nitril 70SH	1	"
# 42	2620024	O.Ring 112 Nitril 70SH	1	"
# 43	2620348	O.Ring 3118 Nitril 70SH	1	"
# 47	2620016	O.Ring 108 Nitril 70SH	1	"
# 51	2623007	Guide ring I/DW 25/2	1	PTFE
55	2300056	Rivet	2	Alluminium
56	T.T.675	Characteristic label	1	Alluminium
57	2305160	Self- tapping screw	2	Carbon steel
59	7406039	Stroke reference ring	1	"
60	2320740	Nut M4 - UNI 5588 - 6s	1	"
# 62	2620242	O.Ring 221 Nitril 70SH	2	Nitril rubber
# 63	2627410	Lip seal GACO E75 DEM 160	1	"
# 64	2623160	Guide ring E/DWR 160	1	PTFE
65	XPR9886	Piston	1	Alluminium
66	XPR9888	Stud	4	Carbon steel

SLAM-SHUT VBC/975 DN 6"

Item	Code	Description	Qt.	Material
67	2321216	Dado M16 - UNI 5588 - 6s	4	"
68	2320016	Washer M16 UNI 6592	4	"
69	XPR9887	Spacer	1	Alluminium
70	XPR100210	Bonnet	1	ASTM A 105
71	7200057	Monitor valve plug	1	Carbon steel and SS tooth
72	7620748	Valve plug guide	1	Carbon steel
73	XPR9883	Upper flange	1	ASTM A 105
74	XPR9884	Bottom flange	1	ASTM A 105
75	XPR9882	Cylinder liner	1	Carbon steel
80	2703735	Spring D=9 De = 85 L=260 it. 9,2	1	"
81	2300132	Screw M8 x 20 UNI5931 - 8.8	2	"
82	XPR9885	Microswitches frame	1	"
83	2860081	Microswitch	1	Alluminium
84	2860083	Microswitch lever	1	Zamak
85	2300115	Screw M6 x 45 UNI5931 - 8.8	2	Carbon steel
86	2300106	Screw M6 x 25 UNI5931 - 8.8	6	"
# 87	2620434	O.Ring 4675 Nitril 70SH	1	Nitril rubber
# 88	2622264	O.Ring 8700 Viton 90SH	1	Flourocarbon rubber
89	2300095	Screw M6 x 16 UNI 5931	16	Carbon steel
# 93	7409872	O.Ring ST.531 Nitril 70SH	1	Nitril rubber
94	7339004	Vent cup	1	Plastic
95	2840418	Vent brass silencer	1	Brass
96	XPR100211	Left frame for pneumatic box	1	Carbon steel
97	XPR100212	Right frame for pneumatic box	1	"

SLAM-SHUT VBC/975 DN 8"

Components and materials list

Rubber and spare parts components.

Item	Code	Description	Qt.	Material	
	6	7805502	Stem	1	AISI 420
#	7	7121520	Valve seat	1	Metal and rubber
	8	7407954	Metalic fasten ring	1	Carbon steel
	9	7510678	Fasten nut	1	Brass
	11	7626437	Guide for balancing stem	1	Carbon steel
	13	7857025	Stroke indicator label	1	Alluminium
	15	7710277	Balancing stem	1	AISI 420
	17	XPR98816	Guide for travel indicator rod	1	Brass
	18	7718047	Nut for travel indicator rod	1	Carbon steel
	19	7535318	Spacer	1	Alluminium
	20	7613831	Guide for stem	1	Brass
	21	XPR98813	Travel indicator rod	1	AISI 303
	23	7739590	Washer	1	Carbon steel
	24	7730008	Male connector	1	Stainless steel
	25	XPR9889	Couplement ring	1	Carbon steel
	27	2301210	Screw M14 x 50 UNI 5737 - 8.8	4	"
	28	2326048	Feather key	1	"
	30	2600555	Bearing	1	"
	31	2600551	Bearing washer	2	"
	32	2301450	Screw M22 x 70 UNI 5737 - 8.8	18	"
	33	2320827	Nut M18 x 1,5 UNI 5589 6s	2	"
	34	7828613	Spring holder	1	"
	35	2301460	Screw M22 x 80 UNI 5737 - 8.8	2	"
#	36	2622066	O.Ring 4100 Viton 90SH	3	Flourocarbon rubber
	37	2325314	Lock washer	4	Carbon steel
#	38	2620448	O.Ring d = 3,53 Di = 291,69 Nitril 70SH	1	Nitril rubber
#	39	2620396	O.Ring 4362 Nitril 70SH	2	"
#	40	2620104	O.Ring 152 Nitril 70SH	1	"
#	41	2620085	O.Ring 4162 Nitril 70SH	1	"
#	42	2620024	O.Ring 112 Nitril 70SH	1	"
#	43	2620348	O.Ring 3118 Nitril 70SH	1	"
#	47	2620016	O.Ring 108 Nitril 70SH	1	"
#	51	2623007	Guide ring I/DW 25/2	1	PTFE
	55	2300056	Rivet	2	Alluminium
	56	T.T.675	Characteristic label	1	Alluminium
	57	2305160	Self- tapping screw	2	Carbon steel
	59	7406039	Stroke reference ring	1	"
	60	2320740	Nut M4 - UNI 5588 - 6s	1	"
#	62	2620242	O.Ring 221 Nitril 70SH	2	Nitril rubber
#	63	2627410	Lip seal GACO E75 DEM 160	1	"
#	64	2623160	Guide ring E/DW R 160	1	PTFE
	65	XPR9886	Piston	1	Alluminium
	66	XPR9888	Stud	4	Carbon steel
	67	2321216	Dado M16 - UNI 5588 - 6s	4	"
	68	2320016	Washer M16 UNI 6592	4	"

SLAM-SHUT VBC/975 DN 8"

Item	Code	Description	Qt.	Material
69	XPR9887	Spacer	1	Alluminium
70	XPR98810	Bonnet	1	ASTM A 105
71	7200058	Monitor valve plug	1	Carbon steel and SS tooth
72	7620749	Valve plug guide	1	Carbon steel
73	XPR9883	Upper flange	1	ASTM A 105
74	XPR9884	Bottom flange	1	ASTM A 105
75	XPR9882	Cylinder liner	1	Carbon steel
80	2703885	Spring D=9,5 De = 85 L=260 it.9,	1	"
81	2300132	Screw M8 x 20 UNI5931 - 8.8	2	"
82	XPR9885	Microswitches frame	1	"
83	2860081	Microswitch	1	Alluminium
84	2860083	Microswitch lever	1	Zamak
85	2300116	Screw M6 x 50 UNI5931 - 8.8	2	Carbon steel
86	2300106	Screw M6 x 25 UNI5931 - 8.8	6	"
# 87	2620440	O.Ring 4850 Nitril 70SH	1	Nitril rubber
# 88	2622288	O.Ring 8900 Nitril 90SH	1	Flouorocarbon rubber
89	2300100	Screw M6 x 18 UNI 5931	16	Carbon steel
# 93	2620445	O.Ring 4975 Nitril 70SH	1	Nitril rubber
94	7339004	Vent cup	1	Plastic
95	2840418	Vent brass silencer	1	Brass
96	XPR100411	Left frame for pneumatic box	1	Carbon steel
97	XPR100412	Right frame for pneumatic box	1	"
			2	"

SLAM-SHUT VBC/975 DN10"

Components and materials list







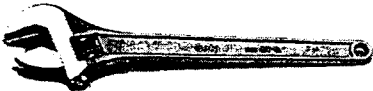
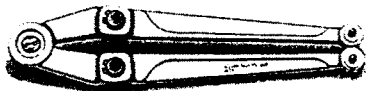

Rubber and spare parts components

Item	Code	Description	Qt.	Material	
	6	7805656	Stem	1	AISI 420
#	7	7121594	Valve seat	1	Metal and rubber
	8	7407958	Metalic fasten ring	1	Carbon steel
	9	7510679	Fasten nut	1	Brass
	11	7626439	Guide for balancing stem	1	Carbon steel
	13	7857026	Stroke indicator label	1	Alluminium
	15	7710280	Balancing stem	1	AISI 420
	17	XPR98816	Guide for travel indicator rod	1	Brass
	18	7718047	Nut for travel indicator rod	1	Carbon steel
	19	7538616	Spacer	1	Alluminium
	20	7613833	Guide for stem	1	Brass
	21	XPR100413	Travel indicator rod	1	AISI 303
	23	7739591	Washer	1	Carbon steel
	24	2401108	Male connector	1	Stainless steel
	27	2300222	Screw M20 x 70 UNI 5931 - 8.8	4	Carbon steel
	28	2326048	Feather key	1	"
	30	2600560	Bearing	1	"
	31	26005601	Bearing washer	2	"
	32	2301470	Screw M22 x 90 UNI 5737 - 8.8	18	"
	33	2320419	Nut M20 x 1,5 UNI 5589 6s	2	"
	34	7828883	Spring holder	1	"
	35	2301480	Screw M22 x 100 UNI 5735 - 8.8	2	"
#	36	2622074	O.Ring 4118 Viton 90SH	3	Flourocarbon rubber
	37	2325320	Lock washer	4	Carbon steel
#	38	2620324	O.Ring 81450 Nitril 70SH	1	Nitril rubber
#	39	2620412	O.Ring 4487 Nitril 70SH	2	"
#	40	2620122	O.Ring 161 Nitril 70SH	1	"
#	41	2620110	O.Ring 155 Nitril 70SH	1	"
#	42	2620036	O.Ring 3056 Nitril 70SH	1	"
#	43	2620104	O.Ring 152 Nitril 70SH	1	"
#	47	2620016	O.Ring 108 Nitril 70SH	1	"
#	51	2623065	Guide ring I/DW 30/2	1	PTFE
	55	2300056	Rivet	2	Alluminium
	56	T.T.675	Caracteristic label	1	Alluminium
	57	2305160	Self- tapping screw	2	Carbon steel
	59	7406039	Stroke reference ring	1	"
	60	2320740	Nut M4 - UNI 5588 - 6s	1	"
#	62	2620242	O.Ring 221 Nitril 70SH	2	Nitril rubber
#	63	2627410	Lip seal GACO E75 DEM 160	1	"
#	64	2623160	Guide ring E/DWR 160	1	PTFE
	65	XPR10016	Piston	1	Alluminium
	66	XPR10048	Stud	4	Carbon steel
	67	2321216	Dado M16 - UNI 5588 - 6s	4	"
	68	2320016	Washer M16 UNI 6592	4	"
	69	XPR10047	Spacer	1	Alluminium

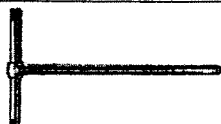
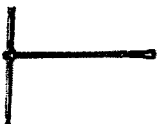
SLAM-SHUT VBC/975 DN10"

Item	Code	Description	Qt.	Material
70	XPR100410	Bonnet	1	ASTM A 105
71	7200059	Monitor valve plug	1	Carbon steel and SS tooth
72	7620750	Valve plug guide	1	Carbon steel
73	XPR10043	Upper flange	1	ASTM A 105
74	XPR9884	Bottom flange	1	ASTM A 105
75	XPR10042	Cylinder liner	1	Carbon steel
80	2704655	Spring D = 12 De = 100 L = 300 it.10	1	"
81	2300132	Screw M8 x 20 UNI5931 - 8.8	2	"
82	XPR9885	Microswitches frame	1	"
83	2860081	Microswitch	1	Alluminium
84	2860083	Microswitch lever	1	Zamak
85	2300116	Screw M6 x 50 UNI5931 - 8.8	2	Carbon steel
86	2300106	Screw M6 x 25 UNI5931 - 8.8	6	"
# 87	2620296	O.Ring 8100 Nitril 70SH	1	Nitril rubber
# 88	2628149	O.Ring 2-450 Nitril 90SH	1	"
89	2300100	Screw M6 x 18 UNI 5931	16	Carbon steel
# 93	2624240	O.Ring 2-380 Nitril 70SH	1	Nitril rubber
94	7339004	Vent cup	1	Plastic
95	2840418	Vent brass silencer	1	Brass
96	XPR100411	Left frame for pneumatic box	1	Carbon steel
97	XPR100412	Right frame for pneumatic box	1	"
98	2330160	Eyebolt	2	"

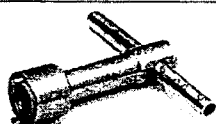
WRENCHES FOR THE MAINTENANCE SLAM - SHUT HBC/975

A	B	C
 Combination spanner	 Adjustable spanner	 Compas pin wrench
D	E	F
 Box spanner	 Hexagon or allen key	 Hexagonal tee key
G	H	I
 Hexagonal socket T wrench	 Phillips screwdriver	 Flat head screwdriver
L	M	N
 O-Ring extraction tool	 Circlip pliers	 Fiorentini special socket
O		
 Fiorentini special tool		

Tipo	DN	6"	8"	10"
A	Ch.	7-17-19-22 24-30-41	7-17-19-22 24-32-41	7-17-19-24 32-50-55
B	L.	300		
D	Ch.	17-21-22-27	17-21-22-27	17-21-30
F	Ch.	5-6	5-6	5-6-17
L	Cod	7999099		

I dati sono indicativi e non impegnativi. Ci riserviamo di apportare eventuali modifiche senza preavviso.
The data are not binding. We reserve the right to make modifications without prior notice.

Pietro Fiorentini s.p.A.

UFFICI COMMERCIALI:
OFFICES:

I-20124 MILANO Italy - Via Rosellini, 1 - Phone +39.02.6961421 (10 linee a.r.) - Telefax +39.02.6880457
E-mail: sales@fiorentini.com

I-36057 ARCUGNANO (VI) Italy - Via E. Fermi, 8/10 - Phone +39.0444.968511 (10 linee a.r.) - Telefax +39.0444.960468
E-mail: arcugnano@fiorentini.com

I-80143 NAPOLI Centro direzionale - Isola G 1 Phone +39.081.7500499 - Telefax +39.081.7500394
E-mail: napoli@fiorentini.com

ASSISTENZA POST-VENDITA E SERVIZIO RICAMBI:
SPARE PARTS AND AFTER-SALES SERVICE:

I-36057 ARCUGNANO (VI) - Italy - Via E. Fermi, 8/10 - Phone +39.0444.968511 (10 linee a.r.) - Telefax +39.0444.968513 - E-mail: service@fiorentini.com